

BRIS

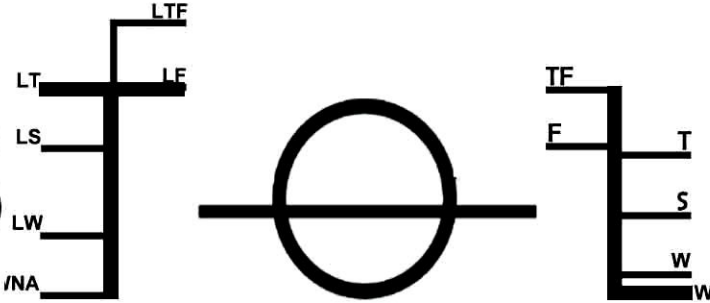

TIDES ?

[Film link 1](#)

[Film link 2](#)

[Film link 3](#)

**BRISTOL**  
2015 EUROPEAN GREEN CAPITAL  
**LOVES TIDES**



# Proxi and Peri

1. Who are these characters?
2. Why have they come to Bristol?
3. Who are they both in love with and constantly drawn to?
4. What themes did they use to score Bristol's love of tides?



# Proxi and Peri Bench Mark Scores

Theme	Proxi and Peri Benchmark Score out of 10	How can we raise the score?
Heritage	9	?
Water	4	?
Biodiversity	6	?
Energy	9	?
Hydropoetics	5	?
Future	7.5	?



# Divide into Six Teams

- Each Team starts with one of the six themes.
- Make a 'fish bone' diagram of all the things that your team thinks causes the score to be lower than 10 for that theme

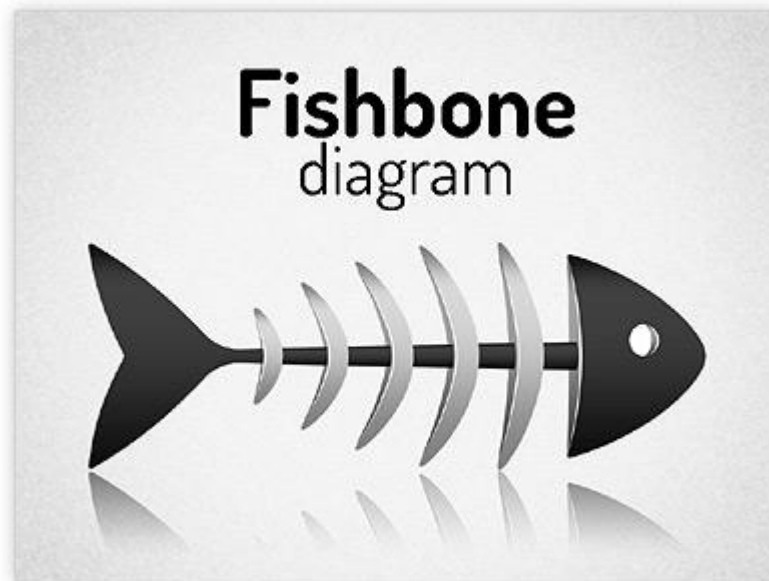

# Fish Bone Diagram

Younger people

People Your age

People in Charge of things

Older people

Eg: Dont recycle plastic



Add things you think are causing a low score to the bones of the fish

Add more bones if you need to

The effect of all this is low scores for not Loving Tides for the theme  
.....

Green Spaces

At Home

Buildings

Places further away from school

Places in or near school

Eg: No trees in school



# Feed back

- Swap your team's fishbone diagram with another team -
- Read their ideas
- Add ideas if you have some
- Swap again
- Do this 5 times until the ideas have been seen by everyone

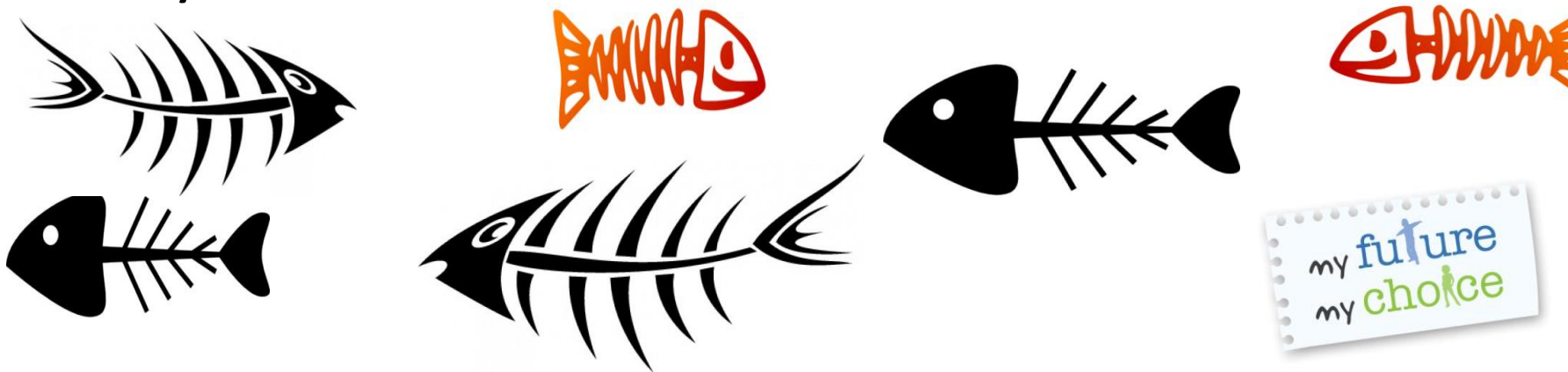

# Ideas for Raising the Scores

List ideas that could improve the scores



# What will make the most difference?

## Place your ideas on to this grid

HIGH IMPACT ON  
RAISING THE  
SCORE

Impact on the Love Tides Score?

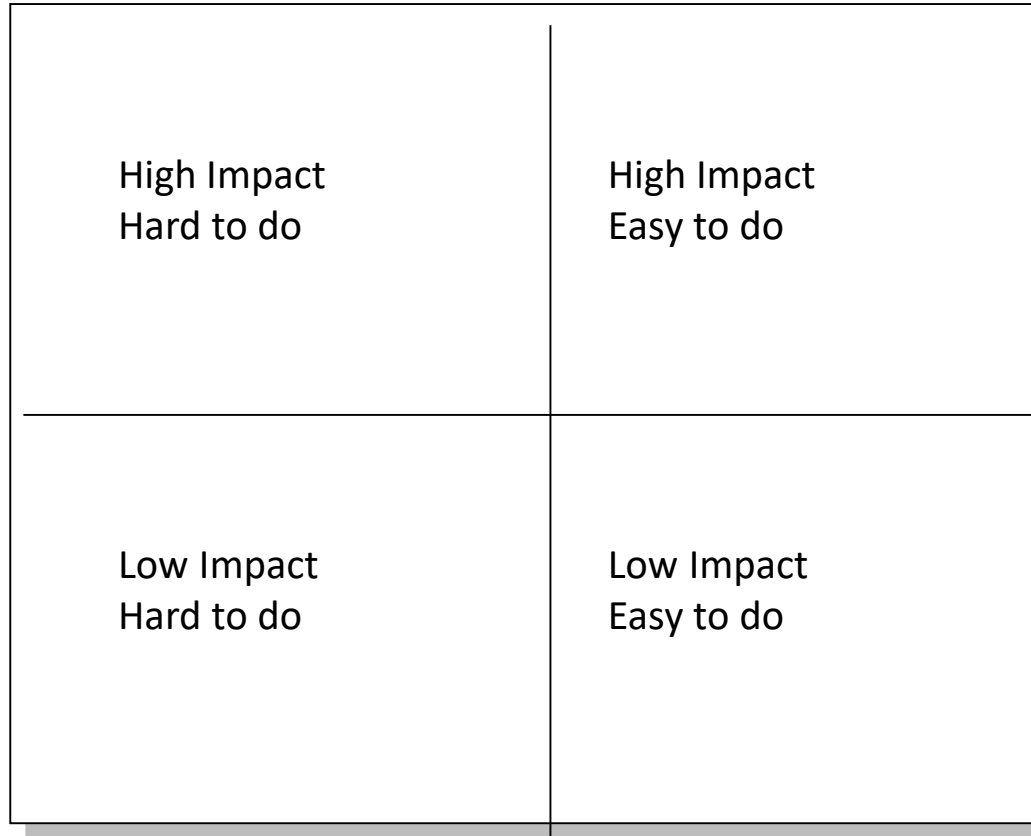

Hard to do

Hard or Easy to do?

Easy to do



LOW IMPACT ON  
RAISING THE  
SCORE