

BRIS   

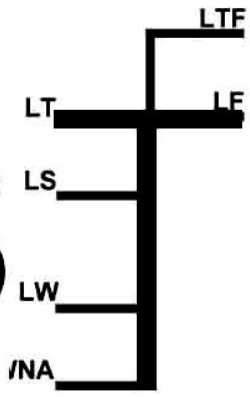

TIDES ?

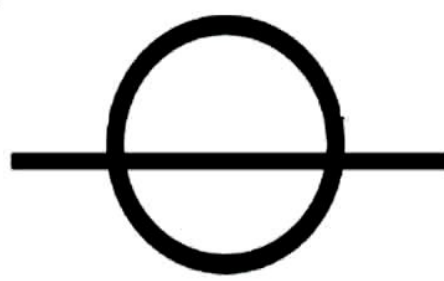
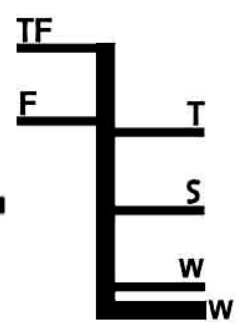

# Proxi and Peri Bench Mark Scores

Theme	Proxi and Peri Benchmark Score out of 10	How can we raise the score?
Heritage	9	?
Water	4	?
<b>Biodiversity</b>	<b>6</b>	<b>?</b>
Energy	9	?
Hydropoetics	5	?
Future	7.5	?



Can seeds survive for more than 100 years?

YES

NO





Have swans lived in the harbour for more than  
100 years?

YES

NO

# YES!

## Swans have been in Bristol's docks for at least 300 years!

- They're here all year, but numbers go up in winter, when birds fly in to benefit from warmer waters and a guaranteed source of food.
- Swans fly away to breed, because of a lack of suitable nest sites in the docks.
- You can tell males from females by their bill – they're brighter orange and have a larger black lump on top.
- Swans sometimes crash land on Bristol Bridge, causing traffic chaos!



Spotted a swan in the harbour?



# Which of these birds can you spot in the harbour?



Gull

Pigeon



Sparrow



Starling



Cormorant



Swan



Look at the map to see the best place to spot the biodiversity -

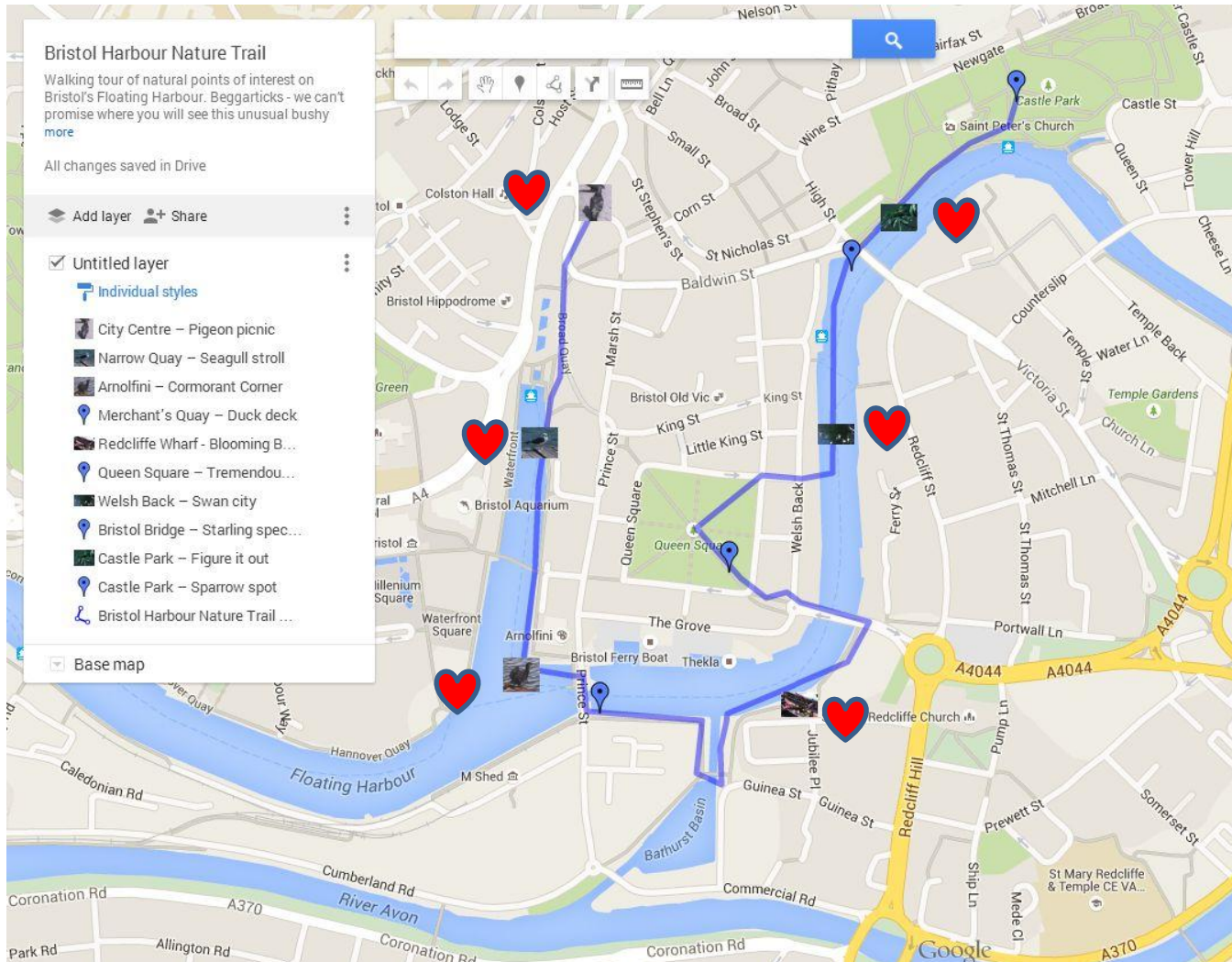

Click on this [link](#) to interact and find out more.  
**Remember to stay safe.**



## But ... it's not all good news the environment could be improved

- There are campaigns happening in Bristol which are supporting the wildlife and trying to increase biodiversity.
- 'Avon Wildlife Group' are trying to improve habitats for wild animals. Here's the [link](#) to tell you about how you could get involved.
- 'City to Sea' are looking at how to minimise plastic waste which are polluting the sea and killing wildlife.

# What can you do?

The World Wildlife Fund has ideas on how you can change the way you live.

Look at their suggestions for:

- [Thinking about your lifestyle](#)

- Make a 'fish bone' diagram of all the things that you think causes the score to be lower than 10 for that theme

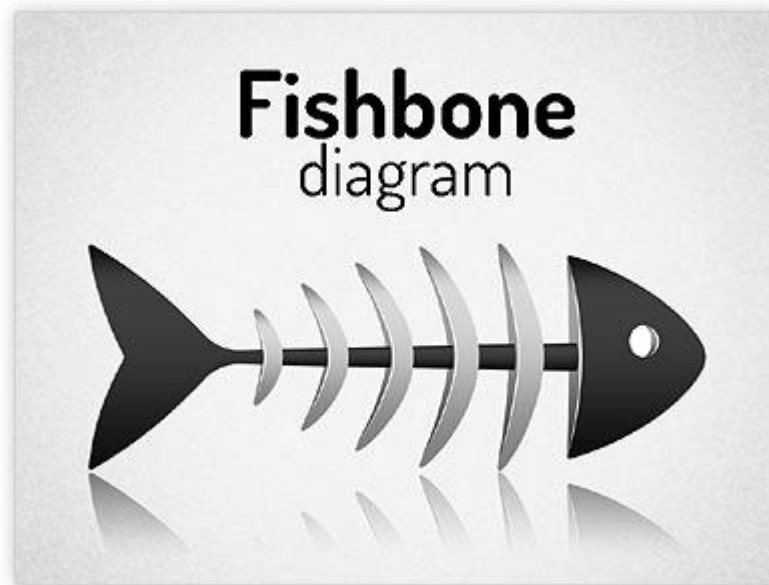

# Fish Bone Diagram

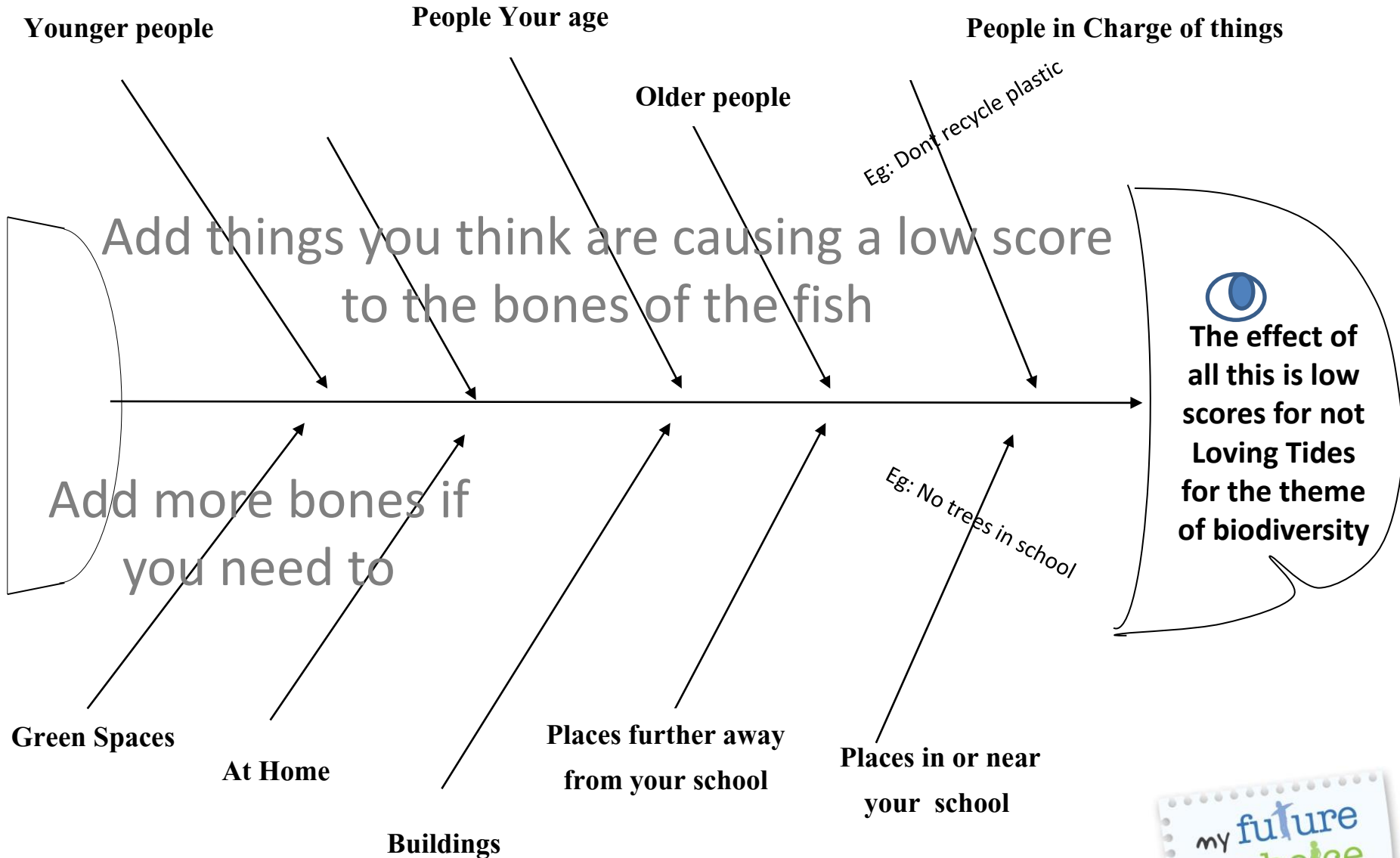

# Feed back

- Send us a picture of your fishbone(s)

Twitter - **@MF\_MC**

Email - **info@myfuturemychoice**

Instagram – **mfmc\_bristol**

