

BRIS   

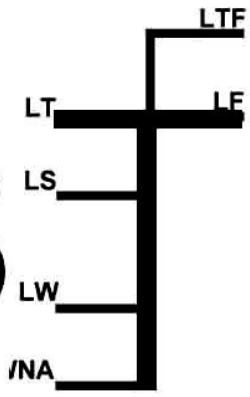

TIDES ?

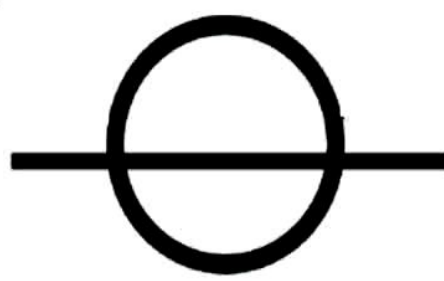
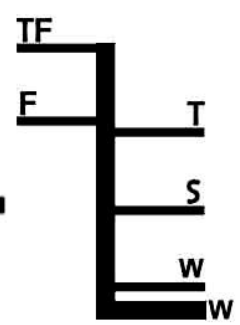

Proxi and Peri Bench Mark Scores

Theme	Proxi and Peri Benchmark Score out of 10	How can we raise the score?
Heritage	9	?
Water	4	?
Biodiversity	6	?
Energy	9	?
Hydropoetics	5	?
Future	7.5	?



What is Hydropoetics?

What is it?

Where can you find it?



Hydropoetics is

- **Art**
- **Poetry**
- **Literature**
- **Music**

That is inspired by water



Read some poems.

Ralph Hoyte was inspired to write a [poetry trail](#) around Bristol's Floating Harbour.

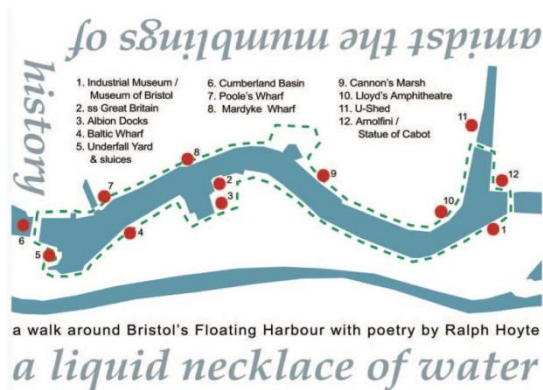

This is part of a poem Ralph wrote at Underfall Yard.

Stick a heart on Underfall Yard on your map 

Mud Welcomes you to the melting pot of the nations. Here all is mud. All secrets ooze in here, all beings come unto... mud. Verily here endeth Man's overweening vanity. Underneath lie the Ganges, the Limpopo: over there the Amazon. Our wellies squelch.

Could you write some tide inspired poems of your own?

Visit a gallery

[Janette Kerr](#) paints pictures of the Sea.

She is so inspired by the sea that she gathered together the work of other artists in an exhibition called '[The Power of the Sea](#)'.

The exhibition was at the [Royal West of England Academy \(RWA\)](#) in Bristol.

Art galleries and Museums in Bristol show many pictures and objects related to the sea and rivers.



Have you visited any galleries?

Have you painted any pictures of the Sea?

Or meander around a Museum



[View on the Avon at Hotwells](#)

by Samuel Jackson Date painted: c.184



[St Mary Redcliffe and Redcliffe Parade from Prince Street Bridge](#)

by Samuel Jackson

Date painted: c.1826

You can see these paintings for yourself at the Bristol Museum.

Listen to some watery music

John Eacott makes music from the movement of tidal water and you can listen to it on [Here](#)

Recently he visited Bristol where he submerged a sensor upstream in the river Avon. The information gathered from the tidal flow is converted into musical notation read from screens or mobile phones by musicians. This allows live notation from the river Avon to be streamed constantly.

No performance of Floodtide is the same, with the music being affected by environmental factors such as wind, air pressure, rain, and even passing boats.

Floodtide is a sonification of tidal flow.

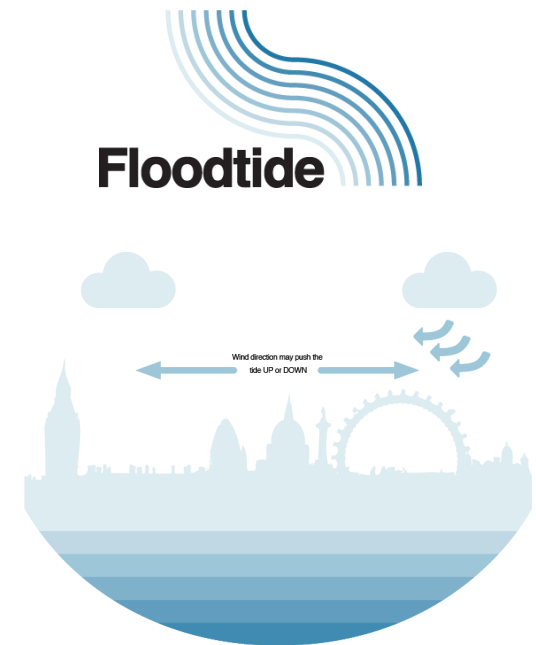

Can you think of ways to make your own watery music?

Make your own Hydropoetics



Plan a water show with pictures, poems, drama and dance or some of these. Use friends and family as your audience if you are not in school.



Feed back

- Send us any poems, films and pictures you make

Twitter - **@MF_MC**

Email - **info@myfuturemychoice.co.uk**

Instagram – **mfmc_bristol**